

# The safe way to fill up with electricity

DFS 4 EV — optimised for wall boxes and charging stations

- preserves the protective function of upstream residual current devices
- also reliably detects smooth DC residual currents exceeding 6 mA
- standard-compliant all-round protection, including IEC 62955

now VDE-  
certified according  
to IEC 62955



# Residual current protection for charging devices

E-mobility is opening up a profitable future market for electrical specialists: the higher the number of electric cars on the roads, the greater the need for charging points. Residual current protection for charging stations, wall boxes and similar devices pose a challenge, but Doepke's residual current circuit-breakers for electric vehicles (EV design) offer a problem-free solution and now comply with the new IEC 62955 product standard.

## Reliable protection for e-mobility

Smooth DC residual currents greater than 6 mA can occur when electric vehicles are charged. This goes beyond the design scope of conventional type A or type F residual current circuit-breakers. In the worst-case scenario, these circuit-breakers may fail as a result of the pre-magnetisation of their summation current transformer, and a failure may go unnoticed.

The IEC 62955 standard includes a residual direct current protective device (RDC-PD) and a residual direct current monitoring device (RDC-MD) under the umbrella term RDC-DD. Residual direct current monitoring devices consist, for example, of a monitoring module for detecting smooth DC residual currents and a switching device (diagram 1). When working with this particular combination, the installer must follow the switch-off criteria required in the event of a fault.

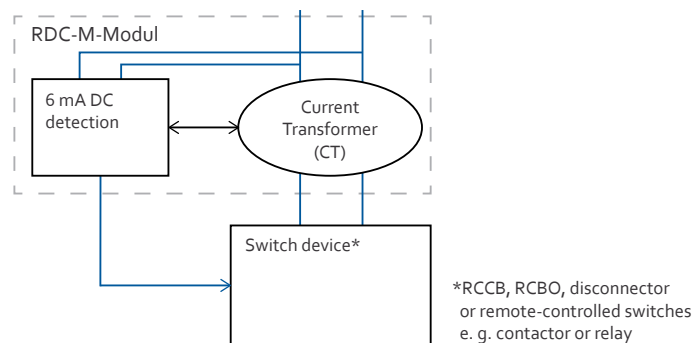

diagram 1: RDC-MD

Our DFS EV residual current circuit-breakers meet the requirements of this standard in just one device (diagram 2). This means that they protect themselves and upstream residual current circuit-breakers reliably against failure, as well as offering users guaranteed protection against hazardous residual currents.

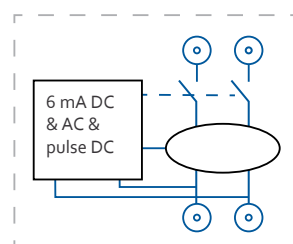



diagram 2: RDC-PD



**Safety** ————— Doepke’s residual current circuit-breakers (EV design) are available in type A version. The DFS 4 A EV detects sinusoidal AC and pulsating DC residual currents, independent of the mains voltage.

	<b>DFS 4 A EV</b> 
detection of pulsating and AC residual currents, not dependent on auxiliary voltage	✓
active additional function for tripping in the event of smooth DC residual currents $\geq 6$ mA	✓
maintains the protective function of upstream type A residual current protective devices	✓
two-pole design	✓
four-pole design	✓
rated current up to 80 A	✓
no other components required per charging socket for residual current protection	✓
certified according the new IEC 62955 standard	✓

## TN-system

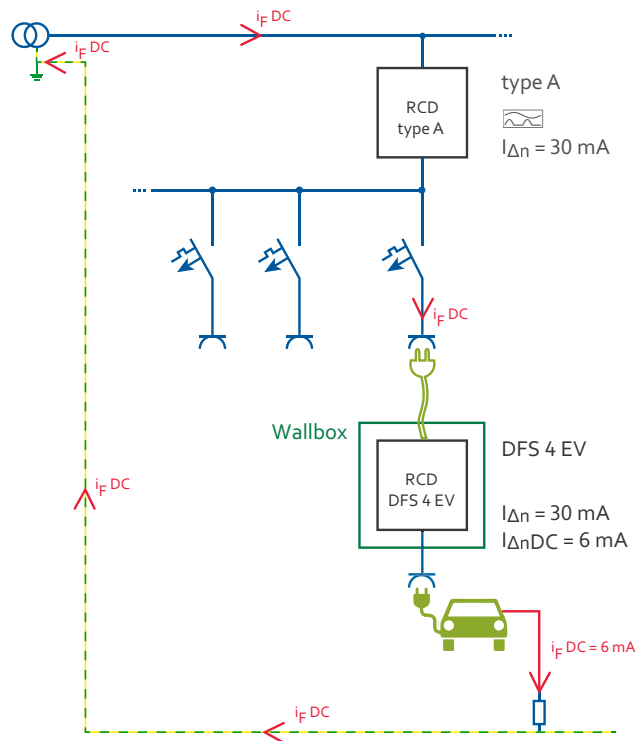

**Case 1:** The charging device is powered from an existing socket protected with a type A residual current circuit-breaker. The standard requires protection against smooth DC residual currents above 6 mA. This protection is guaranteed by DFS 4 EV.







## TN-system

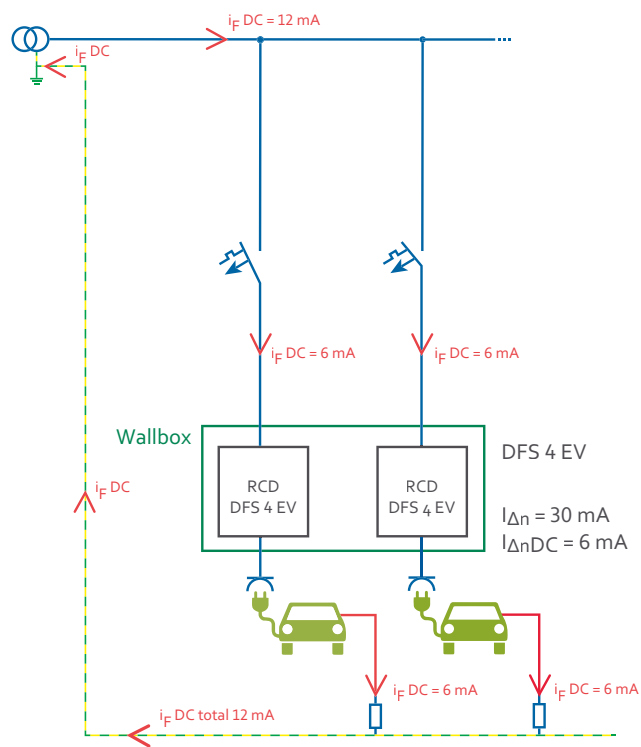

**Case 2:** The charging device has a fixed connection. In this case the installation of one DFS 4 EV per charging point is sufficient. It ensures complete protection against residual currents. There is no need for an upstream residual current circuit-breaker.



## TT-system

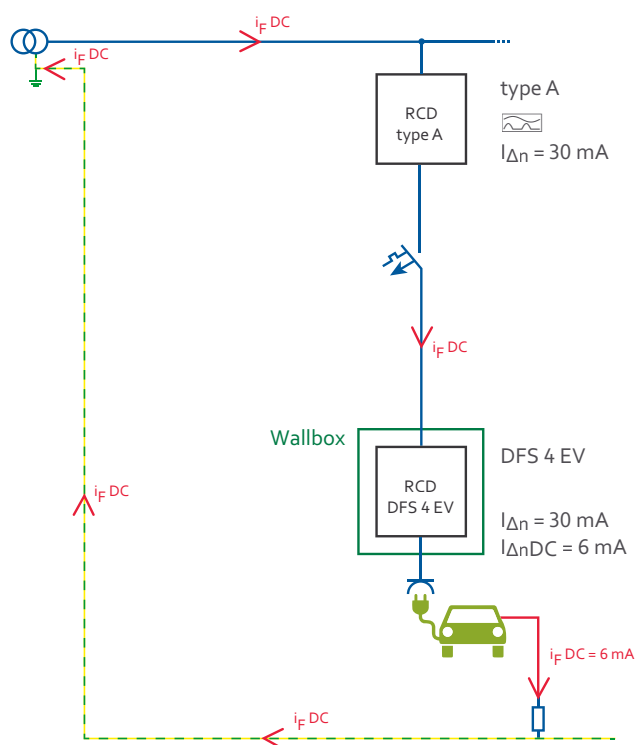

**Case 3:** Switch-off times are subject to stricter rules in this instance. Charging devices with a fixed connection therefore require an upstream residual current circuit-breaker. The downstream DFS 4 EV guarantees the protective function of upstream residual current circuit-breakers even in the event of smooth DC residual currents above 6 mA.



# TT-system

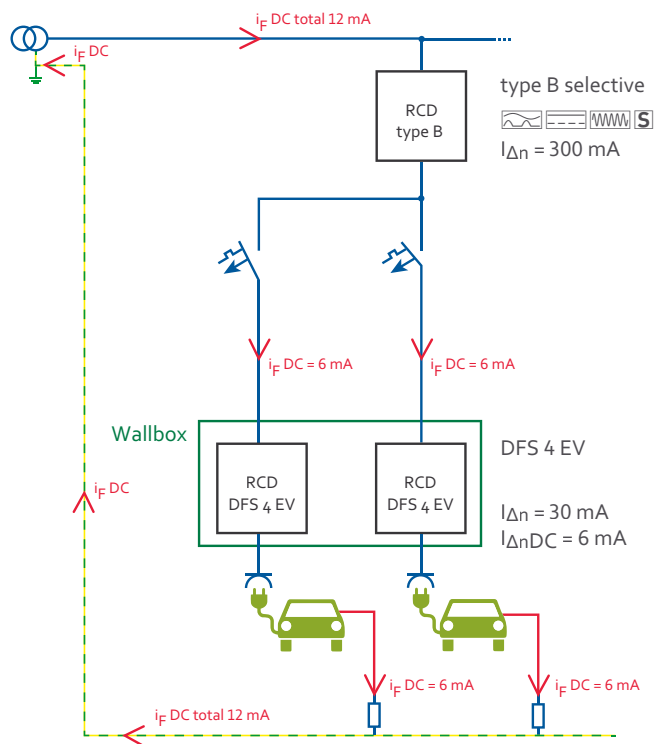

**Case 4:** If several charging devices are placed downstream of a residual current circuit-breaker, the latter must be AC-DC sensitive as the smooth DC residual currents can add up. The EV design provides each charge plug socket with its own residual current circuit-breaker.

**Complete solution for charging points** – Play it safe with Doepke’s residual current circuit-breakers (EV design): the DFS 4 EV devices provide a comprehensive guarantee of the required protection for charging points. Their active additional function means that they offer reliable protection for users and installations, even in the event of smooth DC residual currents above 6 mA. As an easy-to-install complete solution, they obviate the need for additional residual current operated protective devices.

**PREMIUM** | **MARKEN**  
Partner



# Doepke

Doepke Schaltgeräte GmbH  
Stellmacherstraße 11  
26506 Norden | Germany

@ — info@doepke.de  
T — +49 (0) 49 31 18 06-0  
F — +49 (0) 49 31 18 06-101

www — doepke.de