

DLCP 4CH: 4-line DALI-2 Application Controller

The application controller DLCP 4CH allows to manage the operating logic of a DALI-2 system.

Main features:

- x DALI-2 certified according to IEC 62386-101, -103
- x support of special parts of the standard (see paragraph Product properties at the end of this manual)
- x Power supply 100...240V~ 50/60Hz
- x Removable terminal blocks
- x 6 modules housing for DIN rail
- x Integrated DALI bus power supply
- x 4 independent DALI-2 lines
- x 230mA guaranteed current for each line (250mA max each line)
- x Manages up to 64 output addresses (Control Gear) and up to 64 input addresses (Control Devices) for each line
- x Addressing (commissioning) of connected DALI devices
- x Auto detection of connected DALI devices
- x 16 DALI groups for each line + 64 ambients + 8 different scenes for each ambient
- x Ethernet connectivity
- x USB connectivity
- x Information exchange between the 4 DALI lines
- x Information exchange with other controllers or supervisors through the ETH port
- x Integrated WEB server for complete control of commissioning, grouping, programming, diagnostic and much more
- x On-board clock with backup battery for creating scheduling timers
- x Local buttons on front panel for switching on, off and dimming all the connected lamps even in the absence of programming
- x Diagnostic LEDs on front panel
- x Full firmware upgrade through ETH port

Technical characteristics

Power supply	100...240 V~, 50-60Hz
MAX power consumption	20 W
Number of DALI channels	4
DALI bus power supply	15V
Guaranteed DALI current	230 mA (each line)
MAX DALI current	250 mA (each line)
Number of DALI groups	16 (each line)
Number of ambients	64 total
Number of scenes	8 for each ambient
Connectivity	Ethernet port
Standard protocols	MODBUS TCP/I MODBUS RTU over IP
Proprietary protocol	FXP-XT
DALI-2 compliant according to	IEC 62386-101, IEC 62386-103
External protection	6A MCB max
Housing	DIN standard 6-unit
Operating temperature	-5 ÷ +50 °C
Storage temperature	-20 ÷ +70 °C
IP rating	IP20

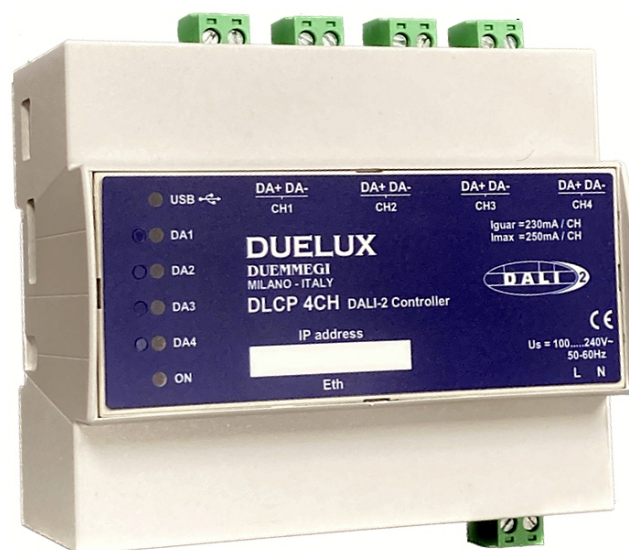

Connection diagram

Provide proper protection at L-N terminals of the module (e.g. MCB circuit breaker 6A max).

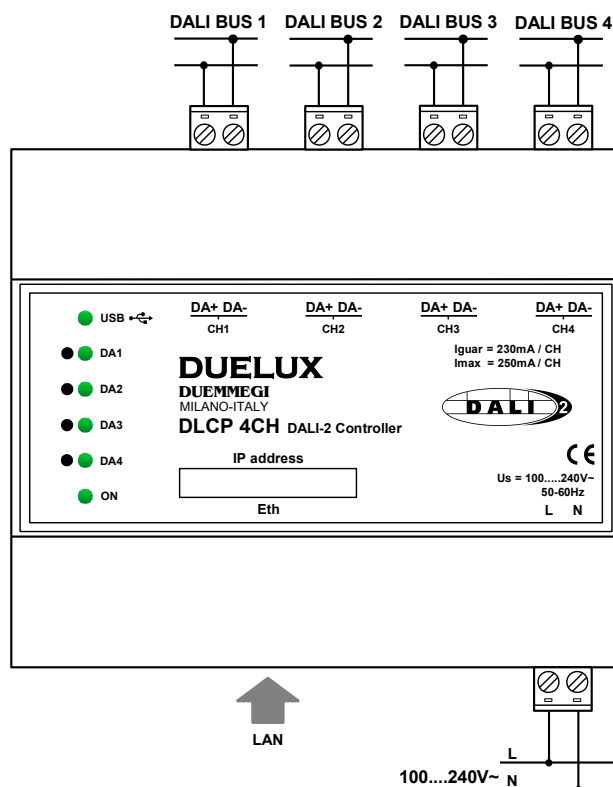

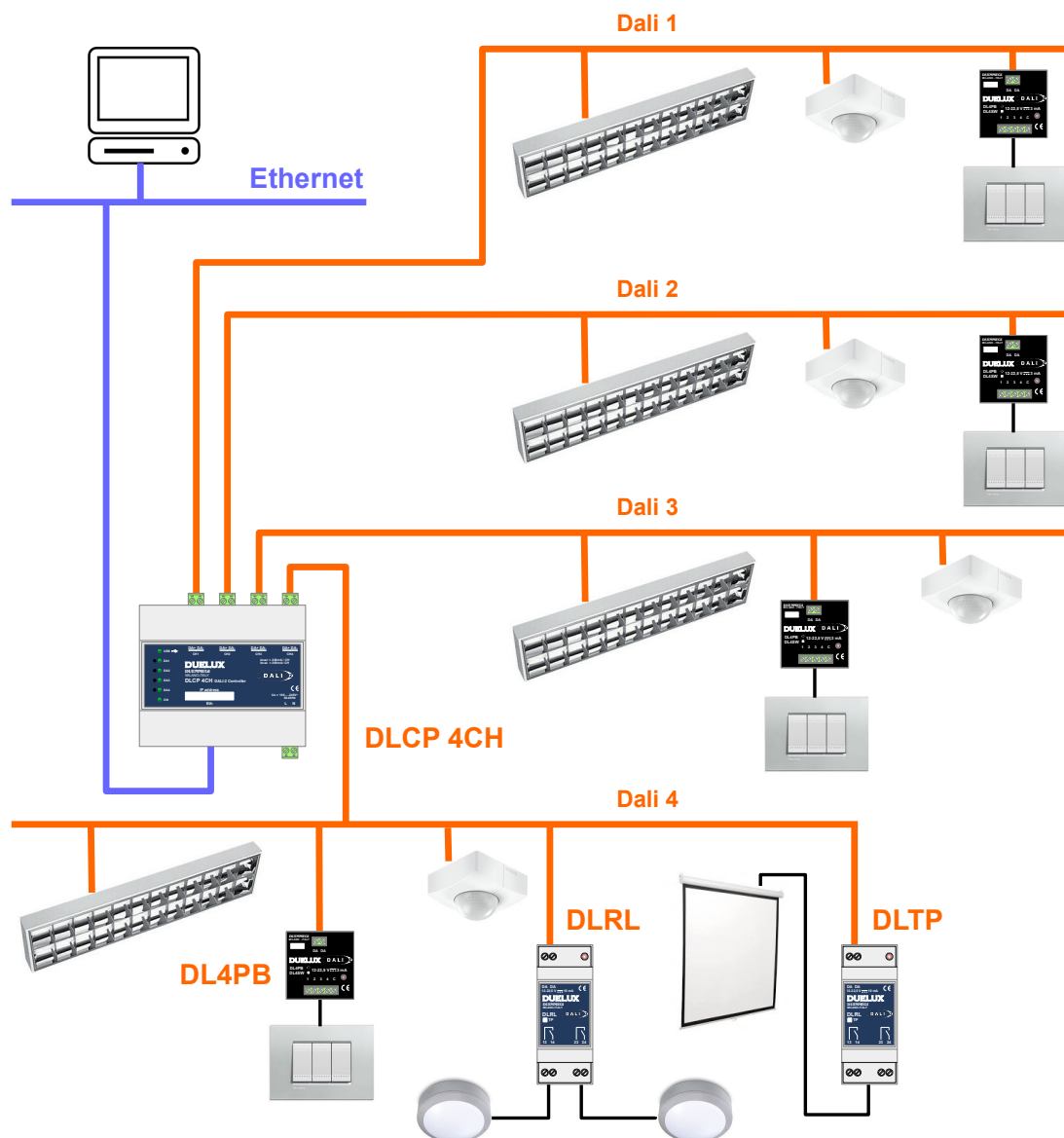

Figure 1: Architecture of DALI-2 system

Architecture of DALI-2 system

The DALI-2 system allows to connect, to the same DALI bus, both the lighting devices and presence and light sensors, buttons and generic inputs, see Figure 1. The difference compared to previous DALI architectures is that it becomes possible to connect to the same bus the “input devices”, thus making DALI-2 a stand-alone system.

The main advantages are:

- x Easier wiring: only one bus for for lighting, switches and sensors
- x Reduction of overall costs
- x Easier programming because all devices belong to the same system
- x Backward compatibility towards lighting devices with previous DALI protocol

The Figure 1 shows the architecture of a system using **DUELUX** DLCP 4CH, with lighting devices (dimmable or ON-OFF using a DLRL module) and input devices distributed on the 4 available lines. The operating logic is managed by DLCP 4CH controller, also through interactions between the 4 lines.

Connectivity

The interfacing to an optional supervisor is guaranteed by the presence, on the DLCP 4CH controller, of an Ethernet port, through which it is possible to access the DALI field. The standard protocols supported are “MODBUS TCP/IP” and “MODBUS RTU over IP”; moreover it is possible to communicate via proprietary protocol FXP-XT.

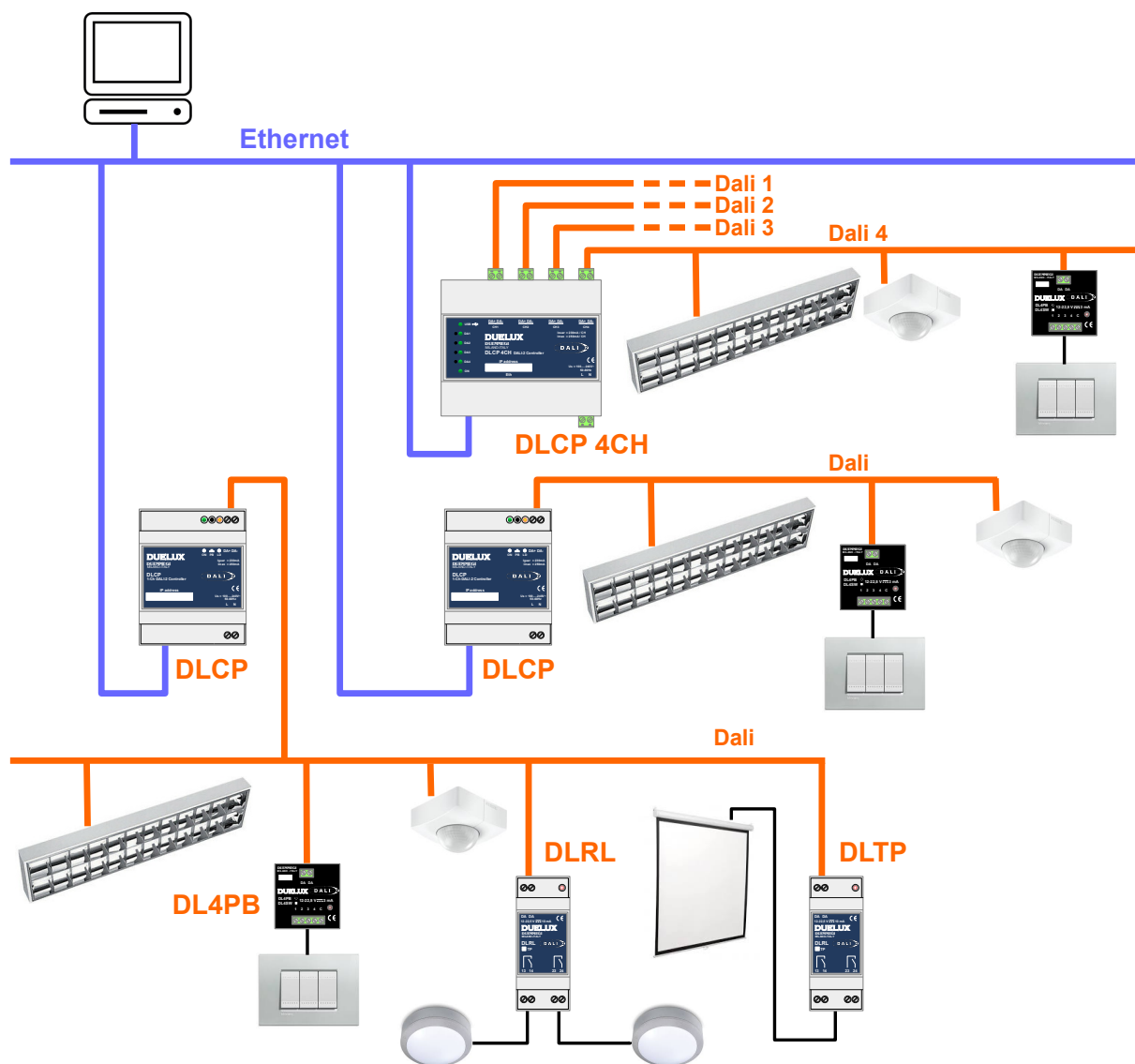

Figure 2: Connectivity between different DALI buses

The same Ethernet port connected to a LAN equipped with a WiFi access point makes it possible to control the system via APP on smartphones and tablets; the user can therefore change the operating parameters of the system as desired (e.g. set point of the light level, activation and deactivation of outputs, etc.).

The Ethernet port also allows to exchange some information between different DALI controllers connected to the same network, see Figure 2; this information can be digital points (e.g. a button on bus 1 turns off all the lights on several different buses), or analog values (e.g. a sensor on bus 3 that controls the light on bus 1).

The Ethernet port also allows to exchange information between DALI buses and other systems connected to the same network (e.g. **CONTRATTO** and **Domino**), see Figure 3.

Amount of DALI-2 devices

DLCP 4CH controller allows to manage, from a logical point of view, up to 64 output devices (ballast, LED driver, etc.) and up to 64 input devices (push button interfaces, sensors, etc.) for each one of the 4 lines. This is the limit of the DALI-2 protocol which provides, in fact, a maximum of 64 addresses for each of the two categories.

The DALI-2 standard also specifies that the maximum current supplied on a bus does not exceed 250mA.

While most of the output devices have a consumption < 2mA as they are powered by an external source (e.g. 230V~), the input devices supplied by the bus itself, for example sensors, need more current and this is declared in the specific manual as explicit value or as number of DALI devices (for example 2 DALI devices mean 4mA).

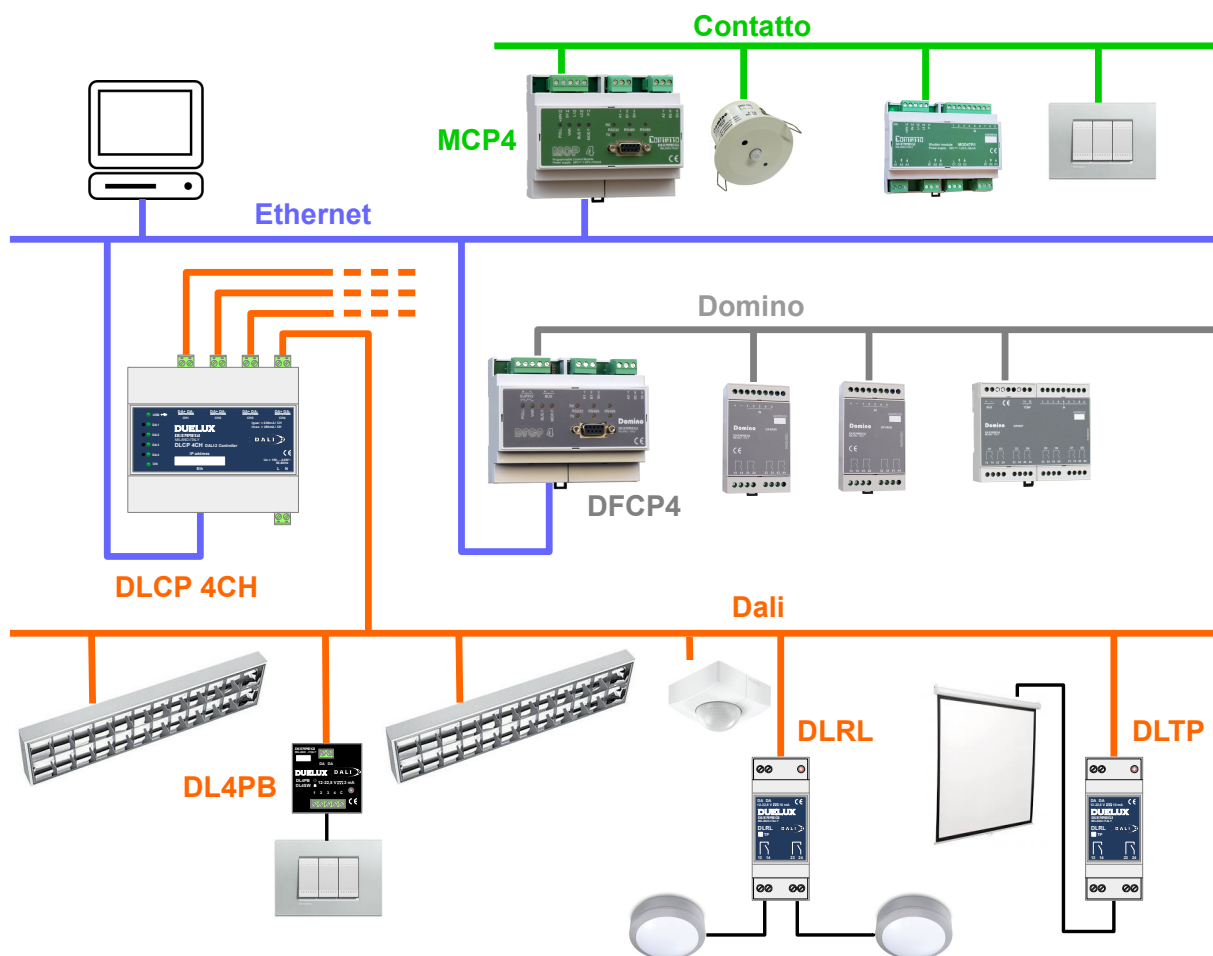

Figure 3: Connectivity to other systems

Therefore the total number of devices that can be connected depends not only on the maximum number of logical addresses, but also on the achievement of the maximum available current. It is therefore recommended, when designing the system, to take into account the current consumption declared for the connected devices.

Shutdown mechanism when short circuit occurs on DALI bus

If a short circuit occurs between DA+ and DA- for more than 1s, the output is turned off; after 2s the output is switched on again and, if still short-circuited for more than 1s, switched off again. Subsequent attempts occur every 14s, until the short circuit is removed.

Diagnostics

The DLCP 4CH module features 6 visible LEDs on the front panel that provide some diagnostic information. ON LED is lighted when DLCP is properly powered. USB LED (green/red) indicates activity on the USB port.

The 4 LEDs DA1, DA2, DA3 and DA4 (green/red) signal activity on the 4 DALI lines as follows:

- x flashing green: indicates the transmission/reception of a message on related DALI line (during very fast procedures it may appear steady lighted)
- x steady red: indicates a fault on the related DALI line, generally a short circuit or in any case an overload beyond the maximum allowed current; in this case it is necessary to check the bus connections
- x flashing red 0.5s ON -0.5s OFF: failure of the related DALI interface
- x flashing red 0.9s ON – 0.1s OFF: failure of one or more DALI device on the related line
- x flashing red 1s ON – 1s OFF: IDENTIFY by DALI command or DLCP scan
- x fast flashing red 0.2s ON – 0,2s OFF: firmware update in progress

Push-button

4 small holes on the left of the LEDs DA1, DA2, DA3 and DA4 allows access to 4 push-buttons which can be operated using a small screwdriver or similar (diameter 2mm).

These buttons have the following functions:

- x short press: switching ON/OFF all output devices (lamps) connected to the related DALI line
- x long press: dimming, if allowed, of all output devices (lamps) connected to the related DALI line
- x restoring the factory configuration of the ETH communication parameters

Regarding the last point above, the factory configuration reset takes place by following these steps:

- 1) turn off DLCP 4CH
- 2) press and hold down any of the buttons relating to DA1-DA2-DA3-DA4
- 3) turn on DLCP 4CH while keeping the button pressed: the 4 Dax LEDs start to flash green
- 4) keep the button pressed until the LED stops flashing (about 20 seconds)
- 5) release the button

Programming: DLCPTools

The programming of a **DUELUX** system does not need any software to be installed, because the programming tool, called DLCPTools, is web-based and integrated in the DLCP controller itself; this makes it possible to manage programming also from PCs with different operating systems but also from devices other than PCs, therefore Tablet and SmartPhone, both IOS and ANDROID.

What it is needed is simply one of the browsers that are commonly installed on the preferred device, so there is no need to install any APP.

DLCPTools also provides a window in the browser that allows to view the virtual "map" of the field, then the levels of lighting devices, the states of digital inputs (buttons, motion and presence sensors, switches, consents) and analog values of the sensors of light.

DLCPTools can generate reports of the configuration for each ambient; this report is basically a table that summarizes, for each ambient, the scenes that have been defined and the logic that has been set up.

For details on programming and using DLCPTools, refer to the specific manual.

Dimensions

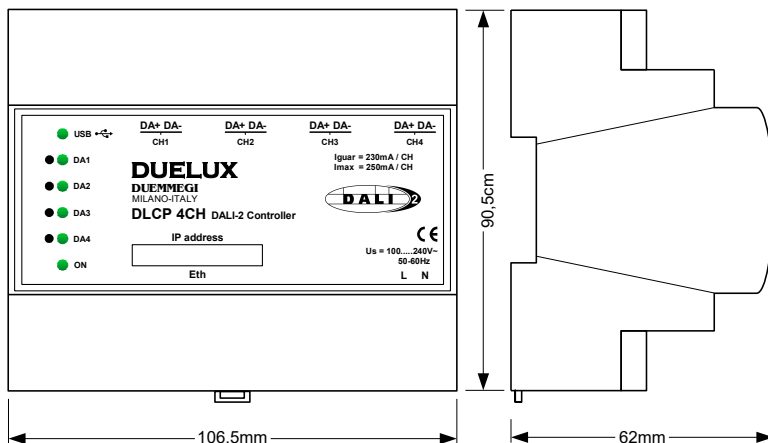

Product properties

DLCP 4CH supports the following DALI-2 special parts of IEC 62386 standard:

- 202: self-contained emergency (DT1)
- 207: LED (DT6)
- 208: switching (DT7)
- 209: colour control (DT8, both type Tc and RGBWAF)

- 251: luminaire data (DT50)
- 252: energy data (DT51)
- 253: diagnostic data (DT52)

- 301: push-buttons
- 302: switches
- 303: occupancy sensors
- 304: light sensors
- 332: feedback of control devices

Correct disposal of this product



(Waste Electrical & Electronic Equipment)
(Applicable in the European Union and other European countries with separate collection systems). This marking on the product, accessories or literature indicates that the product should not be disposed of with other

household waste at the end of their working life. To prevent possible harm to the environment or human health from uncontrolled waste disposal, please separate these items from other types of waste and recycle them responsibly to promote the sustainable re-use of material resources. Household users should contact either the retailer where they purchased this product, or their local government office, for details of where and how they can take these items for environmentally safe recycling. This product and its electronic accessories should not be mixed with other commercial wastes for disposal.

Installation and use restrictions

Standards and regulations

The design and the setting up of electrical systems must be performed according to the relevant standards, guidelines, specifications and regulations of the relevant country. The installation, configuration and programming of the devices must be carried out by trained personnel.

The installation and the wiring of the bus line and the related devices must be performed according to the recommendations of the manufacturers (reported on the specific data sheet of the product) and according to the applicable standards.

All the relevant safety regulations, e.g. accident prevention regulations, law on technical work equipment, must also be observed.

Safety instructions

Protect the unit against moisture, dirt and any kind of damage during transport, storage and operation. Do not operate the unit outside the specified technical data.

Never open the housing. If not otherwise specified, install in closed housing (e.g. distribution cabinet). Earth the unit at the terminals provided, if existing, for this purpose. Do not obstruct cooling of the units. Keep out of the reach of children.

Setting up

The physical address assignment and the setting of parameters (if any) must be performed by the specific softwares provided together the device or by the specific programmer. For the first installation of the device proceed according to the following guidelines:

- Check that any voltage supplying the plant has been removed
- Install and wire the device according to the schematic diagrams on the specific data sheet of the product
- Only then switch on the main voltage supplying the installation
- Proceed to configuration/programming

Applied standards

This device complies with the essential requirements of the following directives:

IEC 62386-101, IEC 62386-103

2014/30/UE (EMC)

2014/35/UE (Low Voltage)

2011/65/UE (RoHS)

Note

Technical characteristics and this data sheet are subject to change without notice.