

RC151UE8 DALI-2 Presence Detector

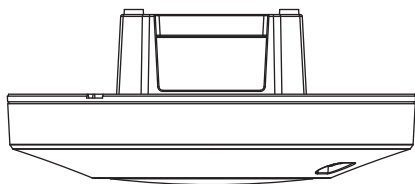

TECHNICAL DATA

Supply Via	DALI
Supply Voltage	10 – 22.5VDC (Typical 16V)
Supply Current	Approx. 8mA
Operating Temperature	-20°C to +45°C
Detection Range	Ø3m (sitting) Ø4m (radial) Ø8m (tangential) at 2.5m height, 20°C
Detection Angle	360°
Lux Setting	1 - 2000 Lux
Ingress Protection	IP20 for flush mount with European standard junction box IP20 for flush mount with spring clip box IP54 for surface mount with surface mount box
Standards	EN 55015 EN/IEC 61347-2-11 EN 61547 IEC62386-101 IEC62386-103 IEC62386-303 IEC62386-304

PACKAGE CONTENTS

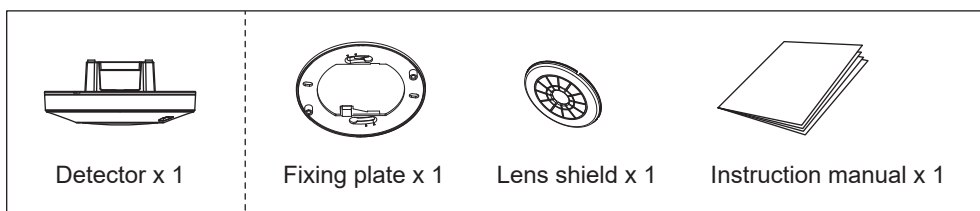

Accessories for optional purchase:

Flush mount spring clips is optional for ceiling flush mount, and surface mount box for surface mount installation.

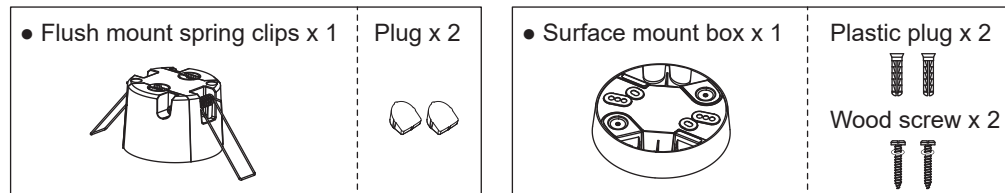

PRODUCT DESCRIPTION

Features

This series is available in various mounting ways, e.g. surface mount and flush mount both applicable, and can fit into the European standard junction box. The accessories surface mount box and back cover with spring clips are for optional purchase to meet different mounting requirement. The Red LED indicator is equipped for sensor function, the Blue LED indicator is equipped DALI-2 identify device.

Dimension

• Detector

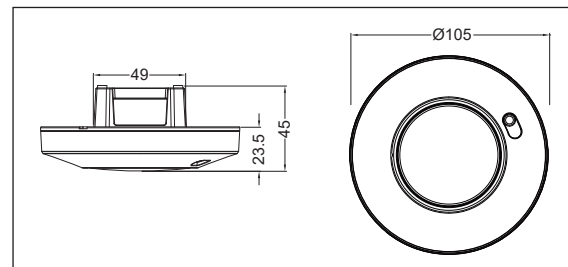

• Detector with surface mount box (optional purchase)

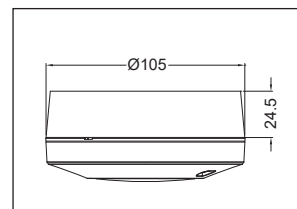

• Detector with flush mount spring clips (optional purchase)

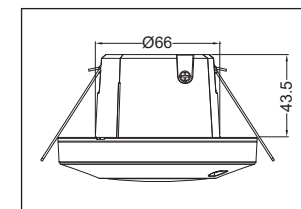

Installation Procedure

• Ceiling flush mount with European standard junction box

1. Take off decorative frame.
2. Pull out power cables from European standard junction box, then strip off 6 - 8mm of cable sheathing for wiring (See FIG.1). Refer to wiring diagrams for correct wiring connection (See FIG.12~13).
3. Please refer to illustration of FIG.2 for correct installation. Fix the fixing plate to the European standard junction box. After wiring, fix the detector to the fixing plate with 2pcs non-dropping screws (See FIG.2).
4. Fix the decorative frame.
5. Restore the power supply.

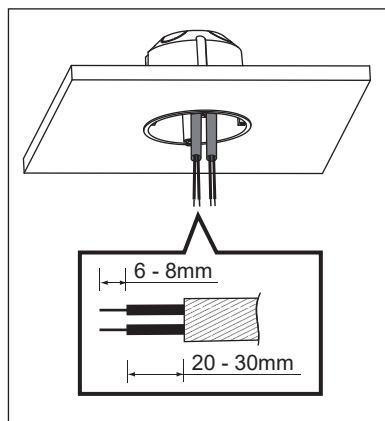

FIG.1

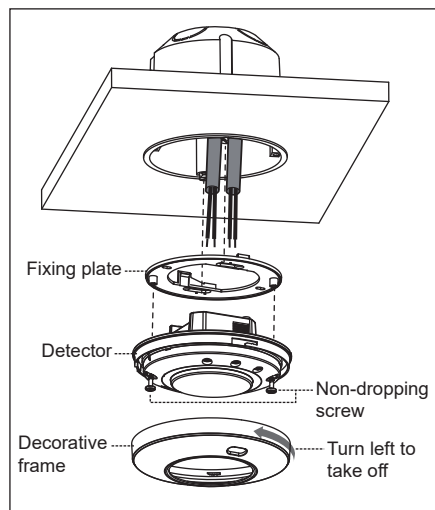

FIG.2

• Ceiling flush mount with spring clips (Optional purchase)

1. To install the detector, please drill a hole with diameter of 68mm on ceiling board and keep the power cable outside. Please strip off 6 - 8mm of cable sheathing for wiring (See FIG.3).
2. Please refer to illustration of FIG.4 for correct installation, and fix the flush mount spring clips to the detector with 2pcs non-dropping screws (See FIG.4).
3. Refer to wiring diagrams for correct wiring connection (See FIG.12~13), and then tighten the flush mount spring clips with 2pcs non-dropping screws (See FIG.4).
4. Raise the two spring clips, and insert the detector into the drilled hole on ceiling (See FIG.5)
5. Restore the power supply.

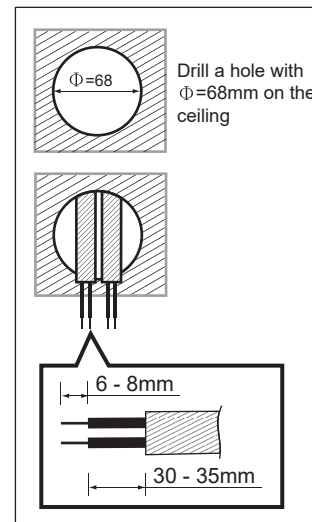

FIG.3

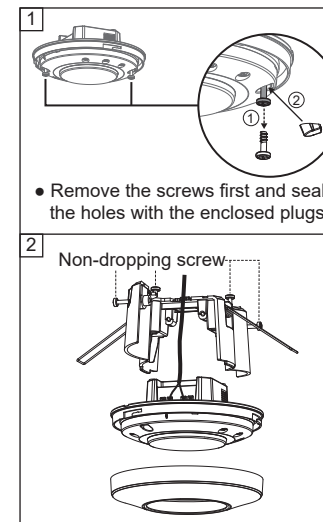

FIG.4

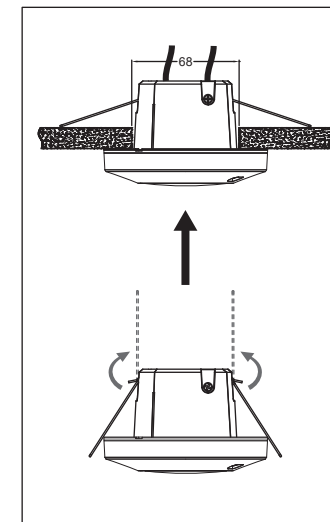

FIG.5

• With surface mount box (Optional purchase)

1. There are 5pairs of knockouts with various distances from 50.8mm to 80mm on the bottom cover of combined surface mount box for different mounting applications (See FIG.6). Select two same figures on both ends for the corresponding distance for fixing (See FIG.7).
2. To feed power cables through the side of surface mount box, please use the cutting pliers to break the cable entry knockouts on the side of surface mount box, then feed the cables through the entry and into the surface mount box. Strip off 6 - 8mm of cable sheathing for wiring (See FIG.8).
3. Choose proper knockouts to fix the surface mount box on the surface of ceiling board with 2pcs wood screws attached with rubber washer (See FIG.9).
4. Refer to wiring diagrams for correct wiring connection (See FIG.12~13) and fix the detector into surface mount box with 2pcs non-dropping screws (See FIG.10).
5. Fix the decorative frame and restore the power supply.

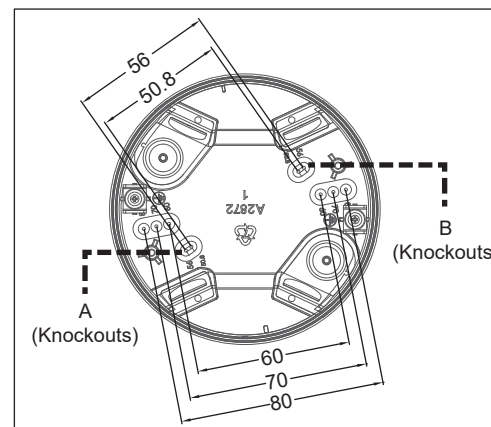

FIG.6

NO.	A	B	The distance between A and B
1	50.8	50.8	50.8mm
2	56	56	56mm
3	60	60	60mm
4	70	70	70mm
5	80	80	80mm

FIG.7

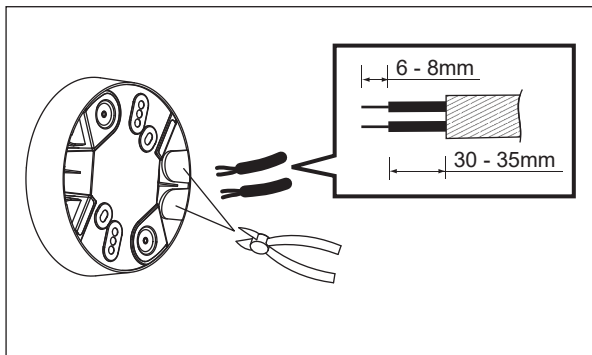

FIG.8

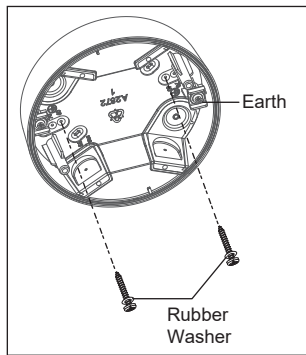

FIG.9

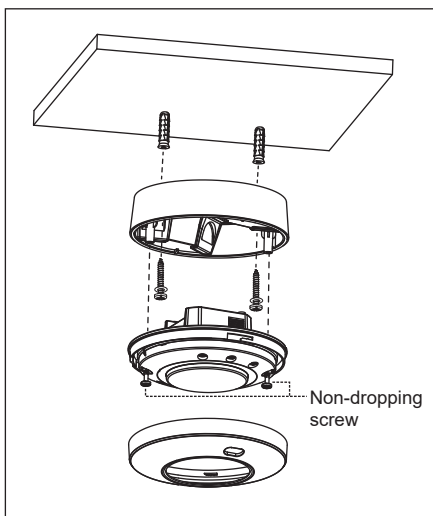

FIG.10

Usage of Lens Shield

Undesired detection areas can be shielded off by fixing the enclosed lens shield onto the lens. Trim the lens shield with scissors either horizontally or vertically until the desired detection area is obtained.

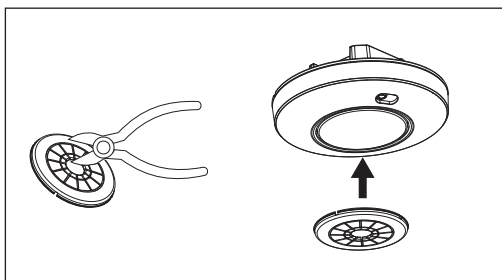

FIG.11

INSTALLATION AND WIRING



- Please disconnect power completely and read the entire instruction manual carefully before installation.
- Installation and assembly of electrical equipment must be carried out by qualified electricians. Contact a qualified electrician in the event of fault or break down.
- The lamp control gear relies upon the luminaire enclosure for protection against accidental contact with live parts.
- If using power tools, ensure that they are set to a low torque setting.

Wiring

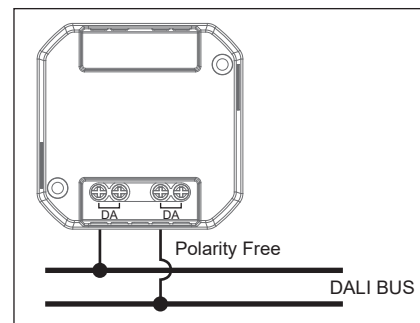

FIG.12

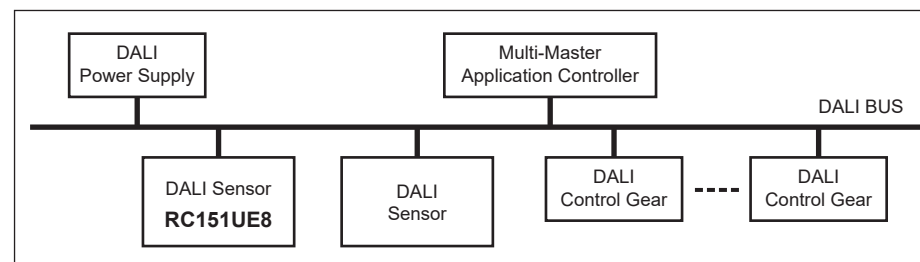

FIG.13

DETECTION RANGE AND ANGLE

Detection Range:

Approx. Ø8m/360° at 2.5m height, 20°C.

- Ø3m (sitting)
- Ø4m (radial)
- Ø8m (tangential)

